

# PRE-ASSEMBLY PREPARATION

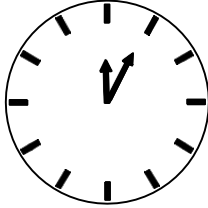

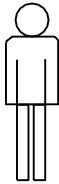

## Before you start:

1. Choose a clean, level, spacious assembly area. Avoid hard surfaces that may damage the product
2. Take care when lifting. Product should be assembled as near as possible to the point of use
3. Ensure that you have all required contents for complete assembly
4. Always read the assembly instructions carefully before beginning assembly
5. Keep all hardware parts and packaging out of small children
6. Do not over tighten the screws and bolts as this may damage the threads

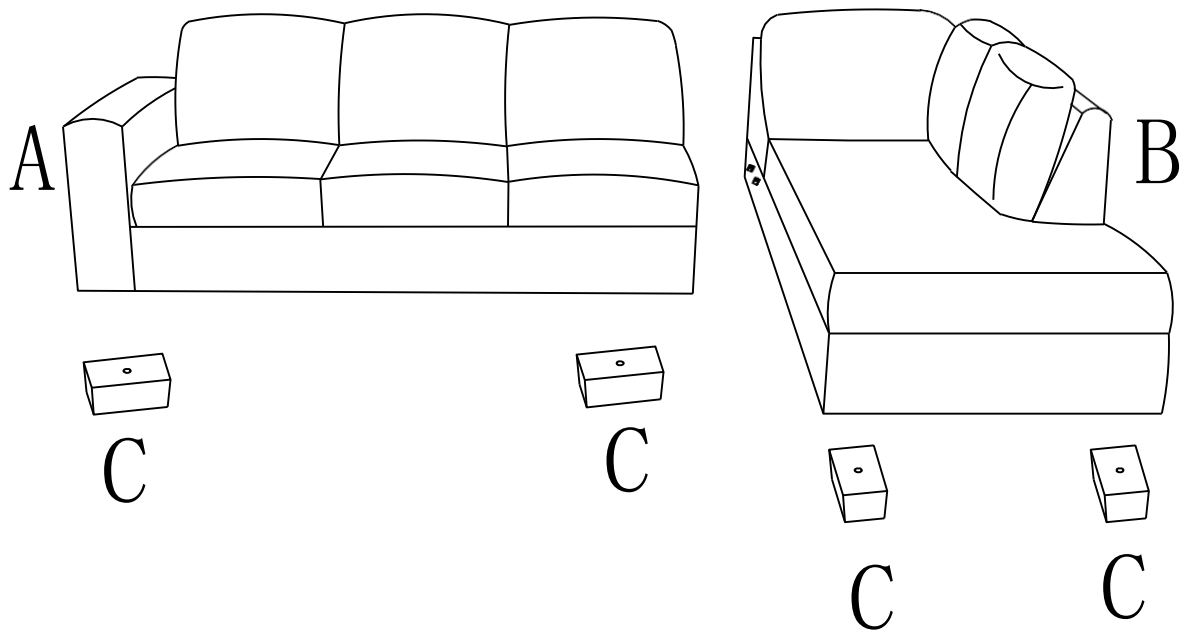
	
ALLOW 5 MINUTES	2 PEOPLE REQUIRED

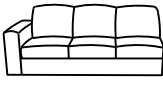
# PARTS LIST

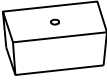

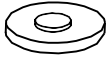
<p>A.1PC</p>  <p>Seat</p>	<p>B.1PC</p>  <p>Chaise seat</p>	<p>C.8PCS</p>  <p>Leg</p>	<p>D.8PCS(M8*60mm)</p>  <p>Bolt</p>	<p>E.1PC(M5*100mm)</p>  <p>Allen Key</p>	<p>F.8PC(M8*16mm)</p>  <p>Flat Washer</p>
--	---	--	--	---	--

**STEP 1** Attach leg(C) to base frame(A) or Chaise seat(B), using bolt(D) with flat washer(F), then fasten by allen key(E). With 2 people carefully turn over

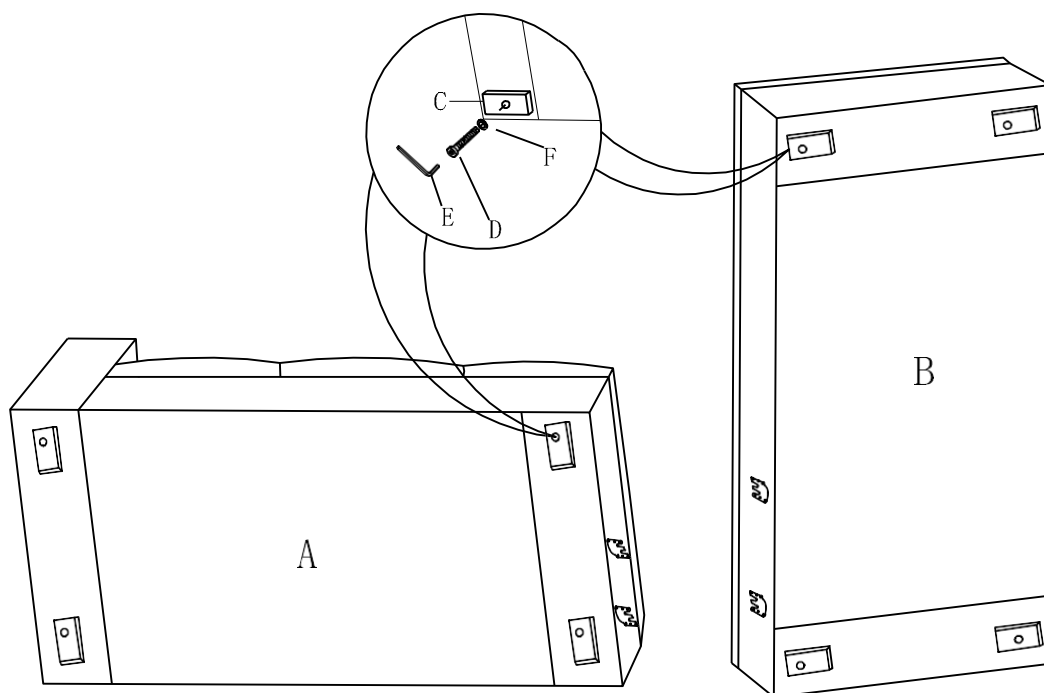

**STEP 2** Attach together as shown in the picture.

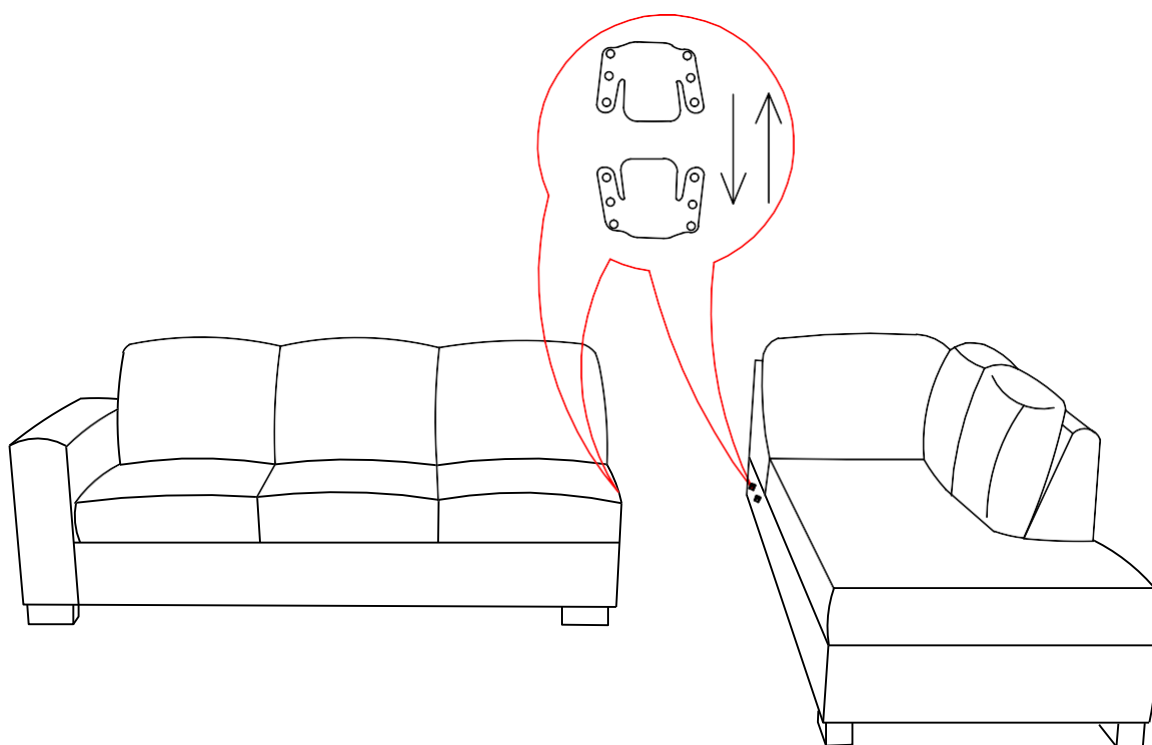

**ASSEMBLY IS COMPLETE**

